



Preisliste 1-2017



**K&W Veranstaltungstechnik
Seefeldhof 1
D-35510 Butzbach**

Tel: 0049 6033 914893

Fax: 0049 6033 914894

Mobil: 0049 171 7536343

Web: kw-veranstaltungstechnik.de

Mail: info@kw-veranstaltungstechnik.de

Systeme

System:	Daten:	Netto-Preis:
 <p>A vertical stack of 12 RCF TT Line Array modules, including 12 x TTL 33A Line Array Modules, 12 x TTS 18A Subwoofers, and 2 x Flugrahmen (flight frames).</p>	<p>RCF TT Großbeschallungssystem bestehend aus:</p> <p>12 x TTL 33A Line Array Module 12 x TTS 18A Subwoofer 2x Flugrahmen</p> <p>Toolcase: 2x Flugrahmen Powerconkabel NF- und Patchkabel Riggingzubehör</p>	<p>795,00</p>
 <p>A JBL VRX System 1 setup featuring 6x VRX 932LA Line Array Modules, 8x SRX718S Subwoofers, 3x Crown XTi 6002 Systemverstärker, and 2x VRX AF Flugrahmen.</p>	<p>JBL VRX System 1:</p> <p>6x VRX 932LA Line Array Modul 8x SRX718S Subwoofer 3x Crown XTi 6002 Systemverstärker 2x VRX AF Flugrahmen</p>	<p>420,00</p>
 <p>A JBL VRX System 2 setup featuring 4x VRX 932LA Line Array Modules, 4x SRX718S Subwoofers, 2x Crown XTi 6002 Systemverstärker, and 2x Stativstange (stands).</p>	<p>JBL VRX System 2:</p> <p>4x VRX 932LA Line Array Modul 4x SRX718S Subwoofer 2x Crown XTi 6002 Systemverstärker 2x Stativstange</p>	<p>275,00</p>

System:	Daten:	Netto-Preis:
	<p>JBL VRX/SRX System 3:</p> <p>2x VRX915M/SRX712M 2x SRX718S 2x Crown XTi 6002 Systemverstärker 2x Stativstange</p>	<p>160,00</p>
	<p>JBL SRX 800 Aktiv-System</p> <p>2x SRX812P 2x SRX818SP Systemverkabelung 2x Stativstange</p>	<p>160,00</p>
	<p>Nova Euphoria Plus:</p> <p>2x Nova EX 600 1x Nova EX318 SUB 1x Nova EX18 SUB P 2x Flugbügel/Stativstange</p>	<p>140,00</p>

Lautsprecher

Lautsprecher:	Daten:	Netto-Preis:
<p>RCF TTL 33-A</p> 	<p>3x8" + 3x1" Aktiv 750 W 60-20000 Hz 100°x15°</p> <p>SPLmax/ 1m 135dB</p>	<p>60,00</p>
<p>RCF TT 02-A</p> 	<p>1x12" + 1x2" Aktiv 1100W LF 500W HF 50-20000 Hz 90°x50°</p> <p>SPLmax/ 1m 134dB</p>	<p>37,00</p>
<p>RCF SUB8004-AS</p> 	<p>1x18" Aktiv 1250W 30-120 Hz</p> <p>SPLmax/ 1m 136dB</p>	<p>35,00</p>
<p>RCF TTS 36-A</p> 	<p>2x18" Aktiv 2x2000W 35-120 Hz</p> <p>SPLmax/ 1m 143dB</p>	<p>70,00</p>
<p>RCF TT 25-SMA</p> 	<p>1x15" + 1x1,5" 500W LF 250W HF 50-20000 Hz 60°x60°</p> <p>SPLmax/ 1m 131dB</p>	<p>35,00</p>



Lautsprecher:	Daten:	Netto-Preis:
<p>JBL VRX 932LA</p> 	<p>1x12" + 3x1" 800 / 1600 W 75-20000 Hz 100°x15° SPLmax/ 1m 130dB</p>	<p>35,00</p>
<p>JBL VRX 915M Bühnenmonitor</p> 	<p>1x15" + 1x1,5" 800 / 1600 W 70-20000 Hz 90°x50° SPLmax/ 1m 133dB Optional auch mit Flugbügel oder auf Stativflansch!</p>	<p>27,00</p>
<p>JBL SRX 718S</p> 	<p>1x18" 800/ 1600 W 34-220Hz Omni SPLmax/ 1m 130dB</p>	<p>25,00</p>
<p>JBL SRX 812P</p> 	<p>1x12" + 1x1" 1500W 40-20000 Hz 90°x50° SPLmax/ 1m 136dB</p>	<p>40,00</p>

Lautsprecher:	Daten:	Netto-Preis:
<p data-bbox="215 181 391 210">JBL SRX 818SP</p> 	<p data-bbox="991 221 1166 358">1x18" Aktiv 1000/ 2000 W 29-150Hz Omni</p> <p data-bbox="962 400 1197 430">SPLmax/ 1m 135dB</p>	<p data-bbox="1326 221 1398 250">40,00</p>
<p data-bbox="215 763 368 792">JBL EON 612</p> 	<p data-bbox="1002 799 1158 974">1x12" + 1x1" 350 LF 150 HF 48-20000 Hz 100°x60°</p> <p data-bbox="962 1016 1197 1046">SPLmax/ 1m 126dB</p>	<p data-bbox="1326 799 1398 828">20,00</p>

Lautsprecher:	Daten:	Netto-Preis:
<p>EV ZXA 5 / EV ZX 5 60B</p> 	<p>1x15" + 1x1" Aktiv 1000W LF 250W HF 58-18000 Hz 90°x50° --- 1x15" + 1x1" 600W / 1200W 58-18000 Hz 60°x60°</p> <p>SPLmax/ 1m 133dB</p>	<p>ZXA 5 - 32,00</p> <p>ZX 5 - 27,00</p>
<p>EV ZXA 1</p> 	<p>1x8" + 1x1" Aktiv 800W 60-20000 Hz 90°x50°</p> <p>SPLmax/ 1m 126dB</p>	<p>20,00</p>
<p>Nova L15A</p> 	<p>1x15" + 1x1" Aktiv 400W 55-18000 Hz 90°x60°</p> <p>SPLmax/ 1m 127dB</p>	<p>24,00</p>
<p>Nova MF120</p> 	<p>1x12" + 1x1" 300W 65-20000 Hz 90°x60°</p> <p>SPLmax/ 1m 122dB</p>	<p>15,00</p>





Lautsprecher:	Daten:	Netto-Preis:
<p>Achat 206</p> 	<p>2x6" + 1x1" 250/ 500W 70-20000 Hz 90°x90°</p> <p>SPLmax/ 1m 119dB</p>	<p>12,50</p>
<p>Achat 110M</p> 	<p>1x10" + 1x1" 250/ 500W 70-20000 Hz 90°x60°</p> <p>SPLmax/ 1m 124dB</p>	<p>15,00</p>
<p>K&W SUB18</p> 	<p>1x18" RCF LF18 900W / 1800W 34-200 Hz Omni</p> <p>SPLmax/ 1m 130dB</p>	<p>25,00</p>
<p>JBL JRX 118S</p> 	<p>1x18" JRX 118S 350W / 750W 4Ohm 38-200 Hz Omni</p> <p>SPLmax/ 1m 129dB</p>	<p>20,00</p>

Controller

Controller:	Daten:	Netto-Preis:
BSS FDS 360 	2 Wege Systemcontroller 2 IN / 4 Out Trennfrequenz 125Hz oder 150Hz	12,50
DBX Driverack PA2 	Mono/2 Wege/ 3Wege Systemcontroller 2 IN / 6 Out Routing, G-EQ, P-EQ, X-Over, Limiter	20,00

Endstufen/ Systemracks



Endstufen:	Daten:	Netto-Preis:
Crown Rack1 	2x XTi 6002 4x1200W @ 8 Ohm 4x2100W @ 4 Ohm 4x3000W @ 2 Ohm	60,00
Crown Rack2 	1x XTi 6002 1x XTi 4002 2x1200W/ 650W @ 8 Ohm 2x2100W/ 1200W @ 4 Ohm 2x3000W/ 1600W @ 2 Ohm	50,00
QSC Rack1 	2xQSC EX4000 4x800W @ 8 Ohm 4x1200W @ 4 Ohm 4x1400W @ 2 Ohm	40,00

Controller:	Daten:	Netto-Preis:
<p>Crown XTi 2002</p> 	<p>2x 475W @ 8 Ohm 2x 800W @ 4 Ohm 2x 1000W @ 2 Ohm</p>	<p>20,00</p>
<p>QSC PLX 2502</p> 	<p>2x 450W@ 8 Ohm 2x 750W@ 4 Ohm 2x 1250W@ 2 Ohm</p>	<p>20,00</p>
<p>QSC GX 5</p> 	<p>2x 500W @ 8 Ohm 2x 700W @ 4 Ohm</p>	<p>15,00</p>
<p>QSC MX3000a</p> 	<p>2x800W @ 8Ohm 2x1200W @ 4Ohm 2x1600W @ 2Ohm</p>	<p>20,00</p>



Mischpulte

Mischpulte:	Daten:	Netto-Preis:
<p>Yamaha CL</p> 	<p>Yamaha CL 3 64 Mono, 8 Stereo 24 Kanal und 2 Master Fader</p> <p>Yamaha CL 5 72 Mono, 8 Stereo 32 Kanal und 2 Master Fader</p>	<p>CL 3 – 230,00</p> <p>CL 5 - 295,00</p>
<p>Soundcraft SiEx</p> 	<p>Soundcraft Si Expression 1 16 Mono, 6 Stereo Bis 54 Mono</p> <p>Soundcraft Si Impact 32 Mono, 4 Stereo Bis 54 Mono 8 VCA</p>	<p>80,00</p> <p>120,00</p>
<p>Soundcraft MPMi 12</p>  <p>Siderack für Soundcraft MPMi 12</p> 	<p>Konferenz-/Livemischpult 12 Mono, 2 Stereo, 3 Auxwege</p> <p>1xFurman Power- Conditioner 1xLexicon MX400 Multieffekt 1xDBX 266XL Compressor 1xDBX 231S 2X31 Band EQ 1xDBX 215S 2X15 Band EQ Inkl. kompletter Verkabelung</p>	<p>MPMi 12 25,00</p> <p>Set Preis: 55,00</p> <p>Siderack 40,00</p>
<p>Soundcraft EPM6</p> 	<p>Konferenz-/Livemischpult 6 Mono, 2 Stereo, 2 Auxwege</p>	<p>10,00</p>

Multicore/ Stagebox

Gerät:	Daten:	Netto-Preis:
<p>Yamaha Rio</p> 	<p>Rio 1608 16 Mono / 8 Out</p> <p>Rio 3224 32 Mono / 16 Out 4 AES/EBU Out</p>	<p>1608 - 35,00</p> <p>3224 - 55,00</p>
<p>Soundcraft Mini Stagebox</p> 	<p>Mini Stagebox 16 16 Mono / 8 Out</p> <p>Mini Stagebox 32 32 Mono / 8 Out 4 AES/EBU Out</p>	<p>MSB 16 - 25,00</p> <p>MSB 32 - 40,00</p>

Funkanlagen/ In-Ear

Mikrofon:	Daten:	Netto-Preis:
<p>Shure QLX-D</p> 	<p>QLX-D 4 Empfänger 534-598 MHz Verfügbar mit: QLX-D 1 Bodypack QLX-D 2 Handsender</p>	<p>40,00</p>
<p>Sennheiser XS Wireless</p> 	<p>Sennheiser XS Wireless Verfügbar mit Handheld oder Bodypack Sender</p>	<p>25,00</p>
<p>Sennheiser In-Ear</p> 	<p>Sennheiser EW300 G3</p>	<p>30,00</p>

Mikrofone

Mikrofon:	Daten:	Netto-Preis:
		
E602	Bassdrum Dynamisch	Auf Anfrage!
E604	Drum Dynamisch	
E606	Gitarre Dynamisch	
E614	Kleinmembran Kondensator	
MD441-U	Dynamisches Mikrofon	
BF541	Dynamisches Mikrofon (ähnlich MD441)	
ME 36	Kondensator Konferenz Mikrofon	
		
SM 57	Dynamisches Instrumenten Mikrofon	Auf Anfrage!
SM 58	Dynamisches Vocal Mikrofon	
Beta 52A	Bassdrum Dynamisch	
Beta 56A	Dynamisches Instrumenten Mikrofon	
Beta 57A	Dynamisches Mikrofon	
Beta 58A	Dynamisches Vocal Mikrofon	
Beta 91A	Grenzflächen Mikrofon	
Beta 98A	Kondensator Miniatur Mikrofon	
		
TG I53c	Kleinmembran Kondensator	Auf Anfrage!
TG I52d	Clip-On Instrumentenmikrofon	
		
AE 5100	Großmembran Kondensator für Instrumenten-/Chorabnahme	Auf Anfrage!
		
C 1000s MK4	Kondensator Mikrofon	Auf Anfrage!
C 419		
Perception 220	Grossmembran Kondensatormikrofon	
		
PAN 01	DI-Box Passiv Mono	5,00
PAN 02	DI-Box Aktiv Mono	7,00
PAN 04	DI-Box Passiv Stereo	8,00

Discomaterial

Mixer/ Case/ Player:	Daten:	Netto-Preis:
Disco Case Denon Bild folgt!	1x Denon X-500 Mixer 1x Denon HC-4500 Controller 1x Denon DN-D4500 MK2	50,00
Allen&Heath Xone:23 	2/4 Kanal Battle-Mixer VCF Filter 3 Band Kill EQ	15,00
Sirius Pro CXS 4000 	CD/ MP3 Player USB Inkl. Fernbedienung	10,00
Technics SL1210 MK 2 	Professioneller DJ Plattenspieler	30,00
Pioneer DDJ SX2 	Pioneer DJ Controller für Serato DJ 2xCD/Line 2xPhono/Line 2x MIC XLR/RCA Output Booth Output	40,00

Statisches Licht

Statisches Licht:	Daten:	Netto-Preis:
<p>6er BAR's</p> 	<p>PAR 64 500W CP87</p>	<p>35,00</p>
<p>4er BAR's</p> 	<p>PAR 64 500W Raylight 1000W CP61 PAR 56 300W CP87</p>	<p>500er 18,00 1000er 25,00 300er 15,00</p>
<p>4er BAR's LED</p> 	<p>Bestückt mit 18x3Watt Showtec LED PAR 64</p>	<p>40,00</p>
<p>4er BAR's LED</p> 	<p>Bestückt mit 7x3Watt Cameo Multi PAR2 kompakte Lichtanlage DMX, Auto-/Soundbetrieb Fernbedienung</p>	<p>20,00</p>
<p>LED Floorspot</p> 	<p>7x 3 in 1 LED's DMX Standalone Sound</p>	<p>6,00 12er Set 50,00</p>
<p>Cameo PixBar</p> 	<p>PixBar 400 Pro 12x8W RGBW PixBar 300 Pro 6x8W RGBW</p>	<p>15,00 4er Set 50,00 10,00 4er Set 30,00</p>

Statisches Licht:	Daten:	Netto-Preis:
<p>ACL BAR's</p> 	<p>2x4er BAR PAR 36 250W/28V</p> <p>2x4er BAR PAR 64 250W/28V</p>	<p>Set 15,00</p> <p>Set 20,00</p>
<p>Blinder</p> 	<p>2xBlinder PAR 36 650W/120V DWE</p>	<p>Set 20,00</p>
<p>Stufenlinse</p> 	<p>Coemar Passo 1000W Inkl. Torblenden</p> <p>Arri T2 2000W Inkl. Torblenden</p>	<p>1000er - 12,50</p> <p>2000er – 32,00</p>
<p>Fluter</p> 	<p>500W 1000W 1500W</p>	<p>500er 3,00 1000er 7,00 1500er 10,00</p>
<p>PAR 64 Floorspot</p> 	<p>Bestückt mit 500W CP87</p>	<p>5,00</p>
<p>Profiler</p> 	<p>750W 26° Iris</p>	<p>15,00</p>

Bewegtes-/Effekt Licht

Bewegtes-/Effekt Licht:	Daten:	Netto-Preis:
<p>JB Varyscan P7</p> 	<p>270W LED CMY Farbmischeinheit 2 Goboräder Goborad 1: 6 drehbare + offen Goborad 2: 9 feststehende Shutter, Prisma, Focus, Dimmer,Iris, Zoom, CTO Filter, Effektrad Zoom 8°-48°</p>	<p>50,00</p>
<p>Cameo Auro Spot 200</p> 	<p>100W LED 8 Farben + Weiß 6 Gobos, drehbar Shutter, Prisma, Focus</p>	<p>25,00</p>
<p>Briteq BT-W36L3</p> 	<p>36x3W CREE LED's 12,5° Optionaler Frostfilter PowerCon IN/OUT Omega Klemme</p>	<p>25,00</p>
<p>Martin RUSH MH6</p> 	<p>12x10W Osram OStar Zoom 10°-60° 2000 Lumen PowerCon IN/OUT Omega Klemme</p>	<p>30,00</p>



Nebelmaschinen/ Effekte

Nebelmaschine:	Daten:	Netto-Preis:
<p>JEM Magnum</p> 	<p>Magnum 2000 1700W 700m³/min Analog oder DMX</p>	<p>2000er 25,00</p>
<p>Cameo Instant Hazer</p> 	<p>Tour Hazer 1500W DMX 1Min Aufheizzeit</p>	<p>30,00</p>
<p>Showtec Atmos F350</p> 	<p>Fazer 1000W DMX 3Min Aufheizzeit 1,5l Tank</p>	<p>15,00</p>
<p>Antari B-100</p> 	<p>Seifenblasenmaschine 1l Tank</p>	<p>10,00</p>
<p>Strobe 1500</p> 	<p>1500W Strobe Analog mit Controller oder DMX</p>	<p>12,50</p>
<p>Showtec Galactic Mk 2</p> 	<p>140mW RGY 32 Muster Master/Slave DMX 512 Scanwinkel +/- 30°</p>	<p>10,00</p>



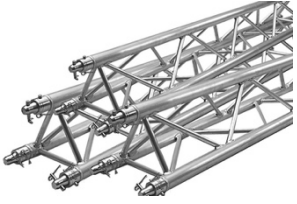
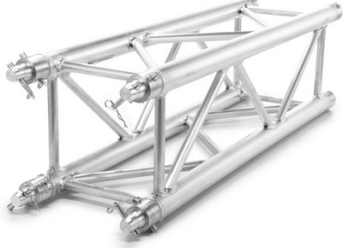

Dimmer/ Lichtsteuerung

Dimmer/ Steuergerät:	Daten:	Netto-Preis:
<p>Ma Lighting</p> 	<p>Command Wing Tourpack Medienrechner onPC Win10 i3 4GB RAM 23,1" Touchscreen</p> <p>2 DMX Universen 2048 Parameter</p>	<p>100,00</p>
<p>GLP Lightoperator</p> 	<p>DMX 512</p> <p>24Kanal oder 48Kanal</p>	<p>24er 10,00</p> <p>48er 15,00</p>
<p>Botex SDC6</p> 	<p>6 Kanal DMX Pult Für einfachste Anwendungen</p>	<p>5,00</p>
<p>Botex MPX 405 / UP 2</p> 	<p>4 Kanal DMX Dimmer Schuko 4x1000W</p> <p>1 Kanal DMX Dimmer Schuko 1x2300W</p>	<p>4 Kanal - 15,00</p> <p>1 Kanal - 6,00</p>
<p>Dimmerrack</p> 	<p>Dimmerrack 12x2,3KW 2xArena 602D 24 Kanal Hotpatch 12 Kanäle einschleifbar Stromverteiler CEE 63A 1X CEE 16A Out 1x CEE 32A Out</p>	<p>60,00</p>
<p>Arena 602D</p> 	<p>6x2,3KW Eingang CEE 16A Ausgang Harting 16 Keine Lüfter, daher ideal für Theater</p>	<p>20,00</p>



Traversen

Traverse/ Rigging:	Daten:	Netto-Preis:
<p>3 Punkt Traverse</p> 	<p>Verfügbar in 2,00 mt 3,00 mt 1,50 mt</p>	<p>per mt 4,00</p>
<p>4 Punkt Traverse</p> 	<p>Global Truss F34 Verfügbar in 0,50 mt 0,875 mt 1,00 mt 1,50 mt 2,00 mt 3,00 mt 3,50 mt 4,00 mt</p>	<p>per mt 6,00</p>
<p>Ecken, T-Stücke, Winkel</p> 	<p>Verfügbar als 2 Wege Ecke 3 Wege Ecke 4 Wege Ecke T-Stück</p>	<p>je 8,00</p>



Lifte/ Rigging

Lifte/ Rigging:	Daten:	Netto-Preis:
<p>Fantek T117B</p> 	<p>Max. Höhe 6,10 mt Min. Höhe 1,90 mt Min. Aufnahmehöhe: 0,20 mt Traglast 250 kg Min. Last 25 kg Eigengewicht 147 kg</p> <p>Stellfläche: 1,84x1,70 mt</p>	<p>45,00</p>
<p>Work LW265R</p> 	<p>Max. Höhe 6,50 mt Min. Höhe 1,84 mt Traglast 220 kg Min. Last 25 kg Eigengewicht 99 kg</p> <p>Stellfläche: 2,00x2,00 mt</p>	<p>30,00</p>
<p>Manfrotto Wind Up</p> 	<p>Max. Höhe 3,80 mt Min. Höhe 1,67 mt Traglast 30 kg Eigengewicht 21,3 kg</p>	<p>12,50</p>
<p>TV Zapfen Stativ</p> 	<p>Max. Höhe 3,50 mt Min. Höhe 1,50 mt Traglast 15 kg Eigengewicht 10 kg</p>	<p>7,50</p>
<p>Chainmaster D8+</p> 	<p>Motor-Kletterzug D8 Plus 250kg</p>	<p>40,00</p>

Video-/Medientechnik

Video-/ Medientechnik:	Daten:	Netto-Preis:
Mitsubishi XL7100U 	6000 ANSI-Lumen XGA	120,00
Sony VPL-4 	2600ANSI-Lumen	25,00
Leinwände 	Verfügbar: 4:3 80" 204cm 4:3 134" 350cm Spanntuchleinwand 200" 500cm Zzgl Stative oder Spannkonstruktion	80" 10,00 134" 20,00 200" 25,00

Bühne

Bühne:	Daten:	Netto-Preis:
Mott Practicus light 	750 kg prp qm 200x100cm Vario Fussatz 60-100cm/100-160cm 20er, 30er, 40er Fussatz Geländer	15,00 je Fussatz 4,00 je Fussatz 2,00 je mt 3,00
Pultdachbühne 	Dach 1: Bühnendach 5m x3,5m Dach 2: Bühnendach 6m x6/8/10m inkl. Podeste, Geländer und Treppe Alle unsere Bühnendächer verfügen über einen Standsicherheitsnachweis!	Auf Anfrage!

Rundbogen-Trailer Bühne



- Spielfläche 6x6m oder 6x4m
- Podesthöhe 1,0m
- Optional mit PA-Wings
- Seiten mit Gaze verkleidet
- Treppe und Absturzsicherung
- Balastfrei
- Aufbauzeit ca. 45Minuten mit 2Personen
- Auf Wunsch mit kompletter Licht- und Tontechnik

Bühne ohne PA-Wings

Netto-Preis: 900,00

Bühne mit PA-Wings

Netto-Preis: 990,00

Preise ohne Anlieferung und Auf-/Abbau

Strom/ Kabel

Strom/ Kabel:	Daten:	Netto-Preis:
CEE 125A Verteiler	Eingang: CEE125 A Abgänge: 2x CEE 63A; 1x CEE 32A; 1x Schuko	50,00
CEE 63A Verteiler	Eingang: CEE 63A Multifunktionsmessgerät Abgänge: 1x CEE 63A; 1x CEE 32A; 3x CEE 16A; 1x Schuko	35,00
CEE 63A Verteiler	Eingang: CEE 63A Abgänge: 2x CEE 32A; 3x CEE 16A; 1x Harting 16; 6x Schuko	25,00
CEE 32A Verteiler	Eingang: CEE 32A Abgänge: 2x CEE 16A 2x Harting 16; 1x Schuko	15,00
Kleinverteiler	16A 32A Schuko	5,00-15,00
Harting Adapter/ Plugboxen 	Diverse Adapter Plugboxen	Auf Anfrage!

Habt ihr etwas nicht gefunden?
Dann fragt uns einfach!!!
Denn fragen kostet nichts!!!

Anfragen an:

K&W Veranstaltungstechnik
Seefeldhof 1
D-35510 Butzbach

Tel: 0049 6033 914893

Fax: 0049 6033 914894

Mobil: 0049 171 7536343

Web: kw-veranstaltungstechnik.de

Mail: info@kw-veranstaltungstechnik.de